

# ***AC7A/B USER'S GUIDE***

**Form 233-981029 — October, 1998**

## **O P T O 2 2**

43044 Business Park Drive, Temecula, CA 92590-3614

Phone: 800/321-OPTO (6786) or 909/695-3000

Fax: 800/832-OPTO (6786) or 909/695-2712

Internet Web site: [www.opto22.com](http://www.opto22.com)

### **Product Support Services:**

800/TEK-OPTO (835-6786) or 909/695-3080

Fax: 909/695-3017

E-mail: [support@opto22.com](mailto:support@opto22.com)

Bulletin Board System (BBS): 909/695-1367

<http://bbs.opto22.com>

(24 hours a day, 7 days a week)

The information in this manual has been checked carefully and is believed to be accurate; however, Opto 22 assumes no responsibility for possible inaccuracies or omissions. Specifications are subject to change without notice.

Opto 22 warrants all of its products to be free from defects in material or workmanship for thirty (30) months from the manufacturing date code. This warranty is limited to the original cost of the unit only and does not cover installation, labor, or any other contingent costs. I/O modules and solid state relays with date codes 1/96 or later, are guaranteed for life.

This lifetime warranty excludes reed relay and dry contact modules. Refer to form number 1042 for more details.

Opto 22 FactoryFloor, Cyrano, Optomux, Pamux, SNAP I/O, Generation 4, and Mystic are registered trademarks of Opto 22. OptoConnect, OptoControl, OptoServer, and OptoDisplay are trademarks of Opto 22.

ARCNET is a registered trademark of Datapoint Corporation.

IBM is a registered trademark and IBM PC, XT, AT, and PS/2 are trademarks of International Business Machines Corporation.

Microsoft and MS-DOS are registered trademarks and Windows is a trademark of Microsoft Corporation.

# TABLE OF CONTENTS

<b>Welcome</b>	<b>4</b>
<b>Chapter 1: Introduction</b>	<b>6</b>
Description .....	6
Features .....	6
Specifications .....	7
Dimensions .....	7
<b>Chapter 2: Installing the AC7A/B for use with Opto 22's Optomux I/O</b>	<b>8</b>
Equipment required for installation .....	8
Mounting the AC7A/B .....	8
Connecting AC Power to the AC7A/B .....	9
Connecting the AC7A/B to your PC .....	10
Setting the AC7A/B RS-232 jumpers (first group - near the 25-pin RS-232 connector) .....	13
Setting the AC7A/B RS-422/485 jumpers (groups B and C) .....	14
Connecting the AC7A/B to the optomux network .....	15
Apply AC power .....	16
Communication LEDs .....	16
<b>Chapter 3: Installing the AC7A/B for use with devices other than Opto 22's Optomux I/O</b>	<b>17</b>
Overview .....	17
Equipment required for installation .....	17
Mounting the AC7A/B .....	17
Connecting AC Power to the AC7A/B .....	18
Connecting the AC7A/B to a PC or other RS-232 device .....	19
Setting the AC7A/B RS-232 jumpers (first group - near the 25-pin RS-232 connector) .....	21
RS-232 Handshaking Signals for Hardware Flow Control .....	23
Setting the AC7A/B RS-422/485 jumpers (groups B and C) .....	24
Connecting the AC7A/B to an RS-422/485 device .....	25
Applying AC power .....	27
Communication LEDs .....	27

**Chapter 4: Additional Technical Information** **28**

General Notes ..... 28

Two-Wire RS-485 mode ..... 29

Commonly Used RS-232 Signals ..... 31

    Using Protective Ground on AC7A/B ..... 32

Biasing and Terminating RS-422/485 ..... 32

    Communication Jumpers ..... 33

Troubleshooting ..... 34

Glossary of Terms ..... 35

RS-422/485 Cable Specifications ..... 36

**Appendix A: AC7A/B DB9 (J2) Connection Pinout** **37**

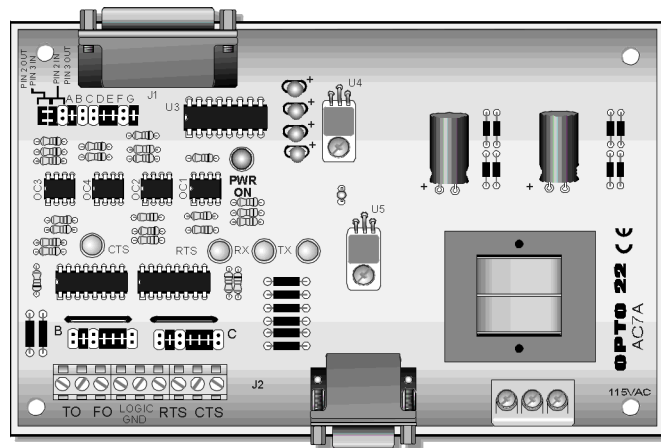
**Appendix B: Product Support** **38**

# WELCOME

## OVERVIEW

---

Opto 22's AC7A/B is an external, standalone, adapter card which converts RS-232 serial communication to RS-422/485 serial communication. The AC7A/B has optical isolation between its RS-232 port and its RS-422/485 port, with full transient protection on the RS-422/485 lines. The AC7A/B is an open chassis circuit board, and is designed to be mounted inside a protective enclosure (protective enclosure not included.) The converter operates as a full duplex device with transmission speeds up to 38,400 baud for distances up to 5,000 feet using two twisted pairs and a ground wire. Revision L and newer AC7A/B's can operate at up to 115,200 baud. The maximum distance for 115,200 baud rate is 3,000 feet.



## ABOUT THIS MANUAL

---

This manual is organized as follows:

- **Chapter 1: Introduction**
- **Chapter 2: Installing the AC7A/B for use with Opto 22's Optomux I/O**
- **Chapter 3: Installing the AC7A/B for use with Devices other than Opto 22's Optomux I/O**
- **Chapter 4: Additional Technical Information**
- **Appendix A: AC7A/B Connection Pinout**
- **Appendix B: Product Support**

## ***ABOUT OPTO 22***

---

Opto 22's goal to deliver total control to industrial automation customers dates back to its beginnings in 1974 with the introduction of optically-isolated solid-state relays. Today, Opto 22 is the number one provider of I/O systems, with more than 50 million points of I/O working reliably worldwide. After earning a reputation for consistent innovation and leadership in automation hardware, Opto 22 realized it was time to take a new approach to control software. In 1988, Opto 22 introduced the first flowchart-based control programming language. Opto 22 continues to deliver successively more advanced generations of hardware and software.

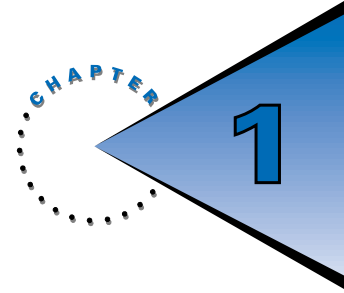
Opto 22's products are organized in a comprehensive 7-layer architecture that establishes the foundation for future innovation and provides strong support for today's customers.

Opto 22 has targeted four key markets: Enterprise, Systems, Components, and Verticals. Opto 22 provides bi-directional data exchange software for integrating manufacturing data into the Enterprise Market, software-driven control solutions for the Systems Market, hardware and drivers for the Components Market, and Vertical Market solutions for the water, energy, and semiconductor industries.

All Opto 22 products are manufactured in the U.S. at the company's headquarters in Temecula, California, and are sold through a global network of distributors, system integrators, and OEMs. Sales offices are located throughout the United States. For more information, contact Opto 22, 43044 Business Park Drive, Temecula, CA 92590-3614. Phone Opto 22 Inside Sales at 1-800-452-OPTO or Opto 22 headquarters at 909-695-3000. Fax us at 909-695-3095.

For fast delivery of marketing and technical documentation, try our free voice-automated OptoFaxBack Service at 1-800-474-6786. You can also visit our Web site at **[www.opto22.com](http://www.opto22.com)**.

# INTRODUCTION



## DESCRIPTION

---

The AC7A/B is an external, standalone, adapter card which converts RS-232 serial communication to RS-422/485 serial communication. The AC7A/B has optical isolation between its RS-232 port and its RS-422/485 port, with full transient protection on the RS-422/485 lines. The AC7A/B is an open chassis circuit board, and is designed to be mounted inside a protective enclosure (protective enclosure not included.) The converter operates as a full duplex device with transmission speeds up to 38,400 baud for distances up to 5,000 feet using two twisted pairs and a signal ground wire. Revision L and newer AC7A/B's can operate at up to 115,200 baud. The maximum distance for 115,200 baud rate is 3,000 feet.

Note: See the solder (non-component) side of the circuit board for the revision number. An example is "001782L" where "L" is the revision letter.

## FEATURES

---

- RS-422/485 balanced line drivers.
- Multidrop capability on the RS-422/485 communication lines.
- Baud rates up to 38,400 baud (up to 115,200 baud for revision L and more current).
- Up to 5,000 feet maximum cable length at 38,400 baud (3,000 feet maximum cable length at 115,200 baud).
- Bi-directional CTS and RTS handshaking lines.
- Optically-isolated up to 4,000 volts between the RS-232 and RS-422/485 lines.
- RS-422/485 lines have transient protection.
- LED indicators for transmit, receive, RTS, CTS, and power.
- On-board power supply.
- Jumper configurable termination and biasing for RS-422/485 lines.

## SPECIFICATIONS

Power Requirements AC7A AC7B	115 VAC $\pm$ 10 VAC @ 50-60 Hz 220 VAC $\pm$ 20 VAC @ 50-60 Hz
Power Consumption	0.1 amps @ 115 VAC 5 watts (dissipation)
Operating Temperature Range	0° C to 70° C 0 to 95% humidity (non-condensing)
Optical Isolation	4,000 VAC between RS-232 and RS-422/485
RS-232 Interface	25-pin, DB-25 female connector
RS-422/485 Interface	Screw terminals or 9-pin, DB-9 female connector
Baud Rate	Up to 38,400 baud (115,200 baud in Rev. L and later)
RS-232 Distance	Up to 50 feet
RS-422/485 Distance	Up to 5,000 feet at 38,400 baud (3,000 feet at 115,200 baud)
Communications	RS-422/485 full duplex over two twisted pairs and a signal ground. Additional twisted pairs for RTS and CTS. Also supports RS-485 2-wire mode. This requires user to build a custom RS-232 cable.
Indicators	Transmit, receive, RTS, CTS, and power.

## DIMENSIONS

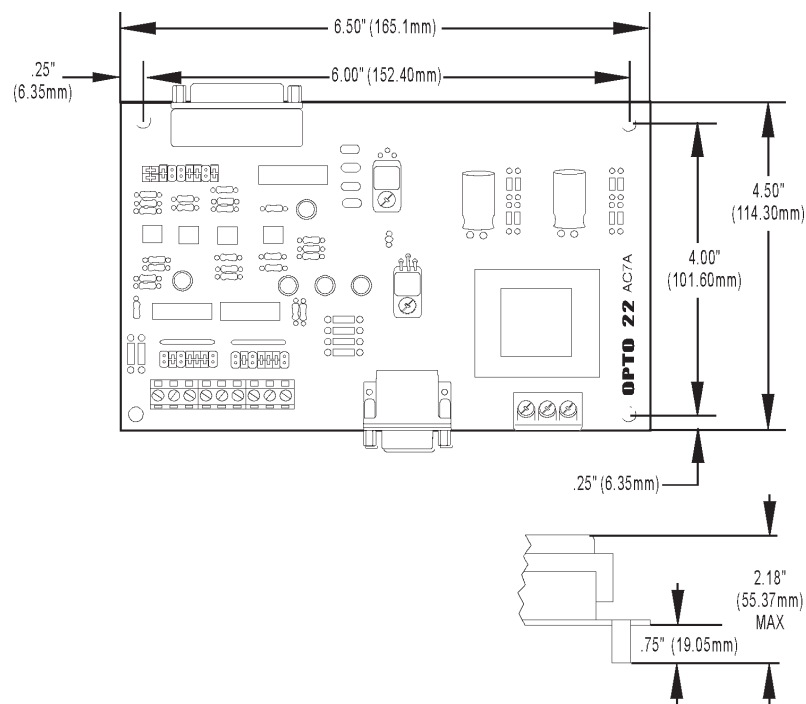
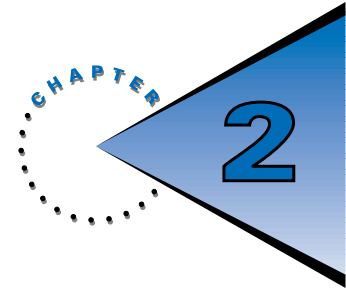


Figure 1-2: AC7A/B Card Dimensions

# ***INSTALLING THE AC7A/B FOR USE WITH OPTO 22'S OPTOMUX I/O***



This chapter gives instructions for installing the AC7A/B adapter card for connecting an Optomux network in 4-wire RS-422/485 mode with a PC.

If you are using the AC7A/B card to communicate with equipment other than Opto 22's Optomux I/O, please see Chapter 3 later in this document. If you would like more detailed information, please see Chapter 4.

## ***EQUIPMENT REQUIRED FOR INSTALLATION***

---

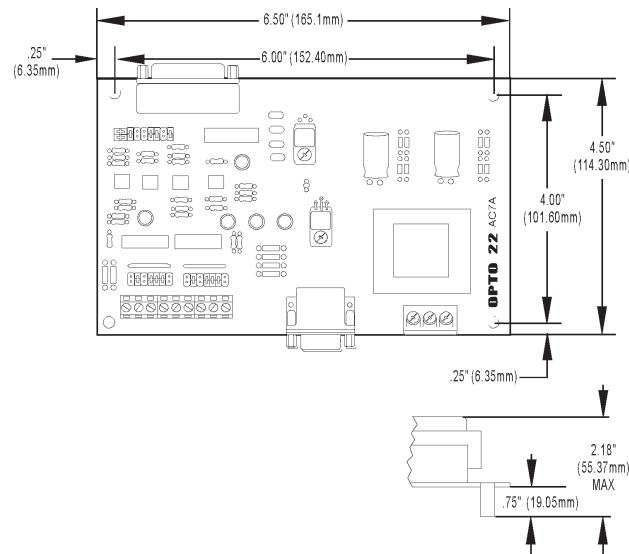
- Medium size flat-blade screwdriver
- Wire stripper
- Variety of color-coded wires and cables:
  - #22 or #24 gauge twisted-pair cable for communication cables
  - #18 gauge for power connections.

## ***MOUNTING THE AC7A/B***

---

The AC7A/B adapter card may be mounted in any position on any flat surface. The AC7A/B is supplied with 3/4" standoffs. All of the standoffs should be secured using #6 mounting hardware to provide maximum physical strength. Sufficient space should be left around the AC7A/B for serial communication cables and for power wiring. Figure 2-1 shows the dimensions of the AC7A/B adapter card.





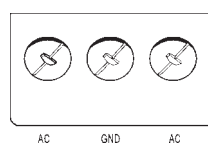
**Figure 2-1: AC7A/B Card Dimensions**

## CONNECTING AC POWER TO THE AC7A/B

**Caution: Make sure that power is OFF** while making or removing all connections to the AC7A/B and Optomux. For safety purposes, a plastic insulating cover is provided for the power terminal block, and should be installed after power wiring is completed.

The AC7A/B has a terminal strip with three screw terminals for AC power. The AC power, which is supplied to the AC7A/B, should have three wires, two for AC power and one for earth ground (usually colored green). Connect the wire for earth ground (usually colored green) to the center screw terminal which is labeled GND. Connect the other two wires to the terminals marked AC, one wire per terminal. The polarity of the AC power wires with respect to the AC screw terminals on the power connector of the AC7A/B does not matter.

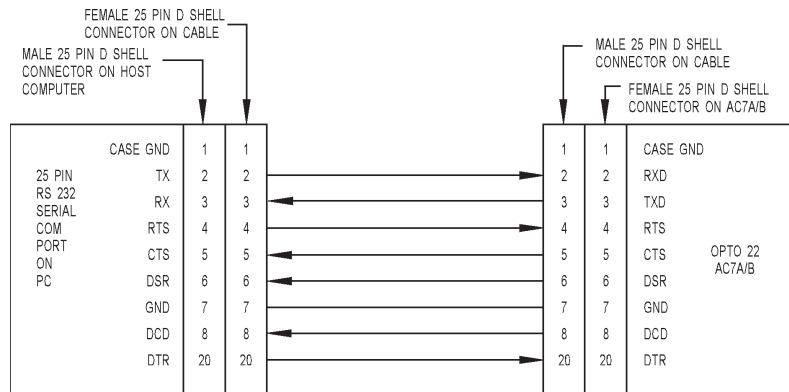
If using a standard, 3-conductor power cord with a three-pronged plug, it should be at least #18 gauge wires or larger. On one end should be the three-pronged plug; the other should have three wires with approximately 1/4" (6mm) of insulation stripped off the end of each wire. Find the wire that corresponds to earth ground (usually colored green) and connect this to the terminal labeled GND. You may determine the ground wire by using an ohmmeter and testing for continuity with the ground pin on the plug. The other two wires should be connected to the terminals marked AC, one wire per terminal. The polarity of the AC power wires with respect to the screw terminals marked AC on the AC7A/B does not matter.



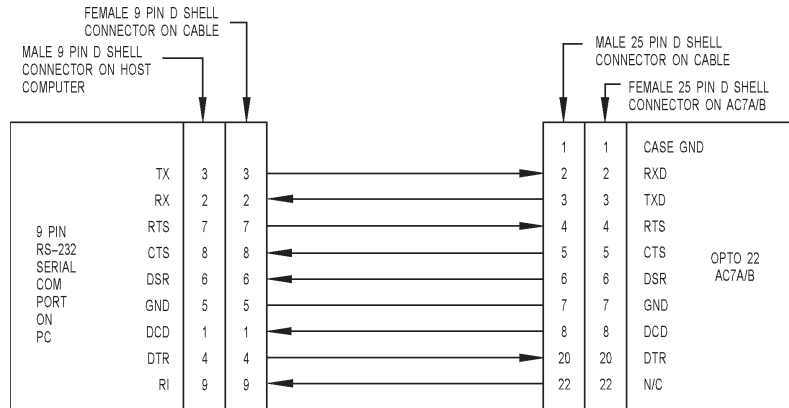
**Figure 2-2: Connector Terminal**

## CONNECTING THE AC7A/B TO YOUR PC

A standard RS-232 serial cable may be used to connect the AC7A/B adapter card to the PC. One end of the RS-232 cable must have a male 25-pin (DB-25) connector for the AC7A/B. The other end of the cable is for the PC, and will most likely need either a 9-pin (DB-9) female connector, or a 25-pin (DB-25) female connector, depending on your computer.

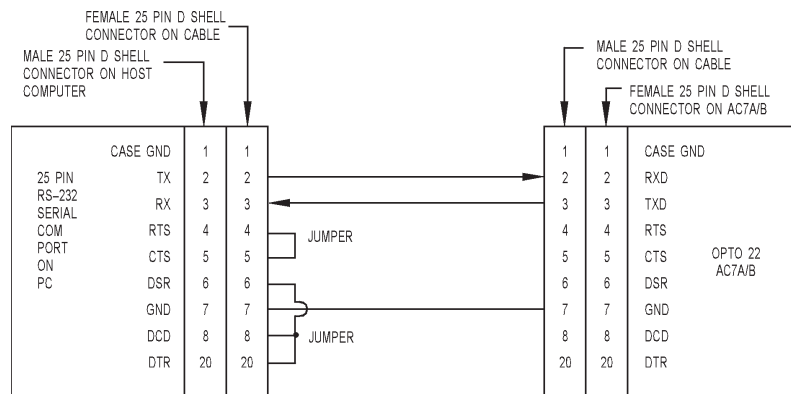


**Figure 2-3: Standard Straight-Through 25-Pin to 25-Pin RS-232 Cable**

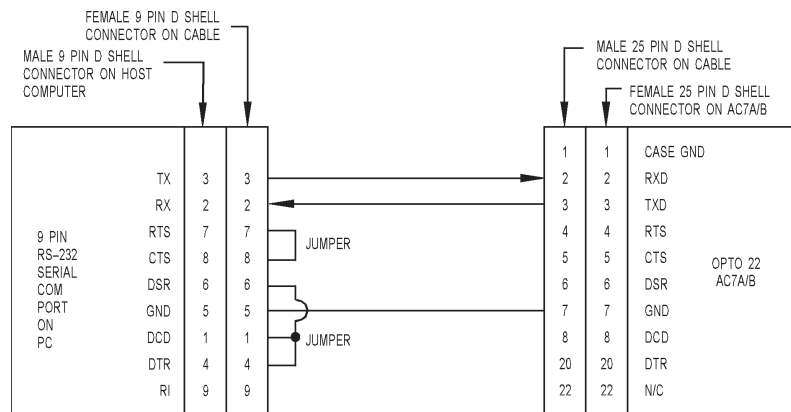


**Figure 2-4: Standard Straight-Through 9-Pin to 25-Pin RS-232 Cable**

It is also possible to make your own cable for connections between the AC7A/B and an RS-232 device. The only connections that are absolutely necessary are transmit and receive (RS-232 pins 2 and 3) and signal ground, which is pin 7 of standard 25-pin connectors. Ground is usually pin 5 on 9-pin RS-232 connectors. (Note: the 9-pin connector on the AC7A/B adapter card is for RS-485, not RS-232. This sections applies only to the 25-pin [DB-25] RS-232 connection on the AC7A/B adapter card.)

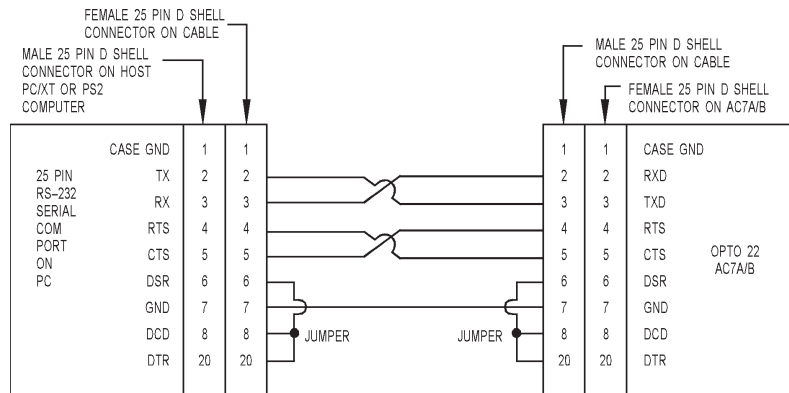


**Figure 2-5: 25-Pin to 25-Pin, 3-Wire RS-232 Cable (made by user)**

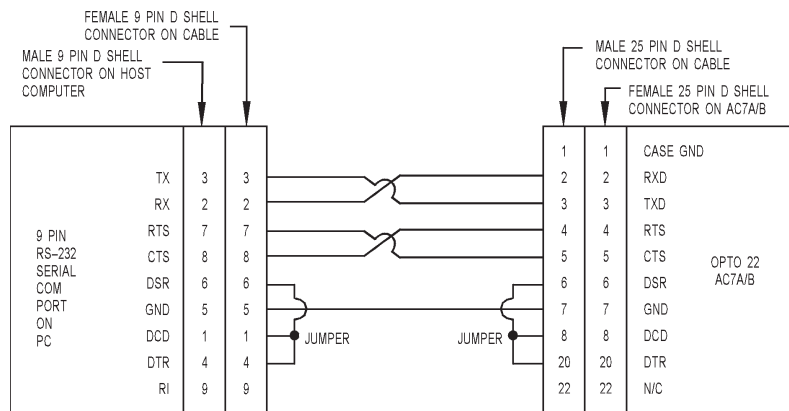


**Figure 2-6: 9-Pin to 25-Pin, 3-Wire RS-232 Cable (made by user)**

**Note:** Some serial cables that look like standard straight-through cables are actually null modem cables. The wiring diagram for a **NULL** modem cable is shown below:



**Figure 2-7: 25-Pin to 25-Pin Null Modem Cable Diagram**



**Figure 2-8: 9-Pin to 25-Pin Null Modem Cable Diagram**

To determine whether you have a null-modem or standard cable, perform the following tests:

**If you have a cable with 25-pin connectors at both ends**, then test the cable for electrical continuity between pin 2 on one end of the cable and pin 2 on the other end. These two pins are tied together on a standard 25-pin to 25-pin straight-through cable. In a 25-pin to 25-pin null-modem cable, pin 2 of one end is tied to pin 3 of the other end.

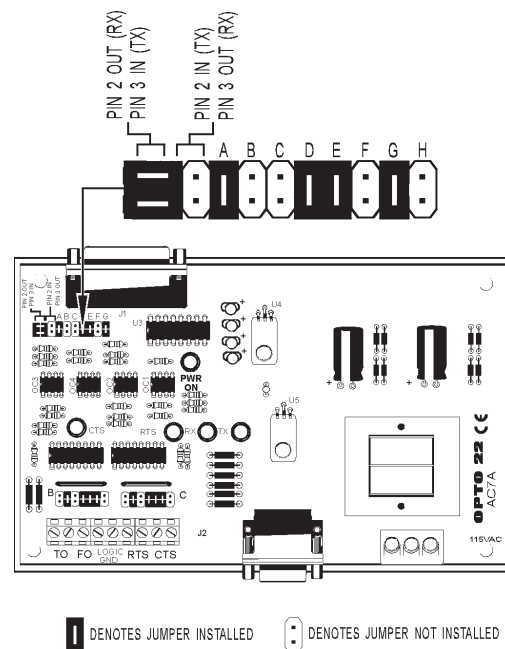
**If you have a cable with a 25-pin connector at one end, and a 9-pin on the other end**, then test the cable for electrical continuity between pin 2 on one end of the cable and pin 3 on the other end. These two pins are tied together on a standard 25-pin to 9-pin straight-through cable. In a 25-pin to 9-pin null-modem cable, pin 2 of one end is tied to pin 2 of the other end.

## SETTING THE AC7A/B RS-232 JUMPERS (FIRST GROUP - NEAR THE 25-PIN RS-232 CONNECTOR)

This group of jumpers is located right next to the DB-25 connector on the AC7A/B. The first 6 pins of the group are labeled *PIN 2 OUT*, *PIN 3 IN*, and *PIN 2 IN*, *PIN 3 OUT*. The rest are labeled by the letters A through H.

This group of jumpers determine which pin on the DB-25 connector is used for transmitting data as well as routing options for other pins. Detailed information about this is covered later in this manual in Chapter 4.

If you are using a standard straight-through cable to connect the AC7A/B to your PC, then set these jumpers as shown below:



**Figure 2-9: Jumper Settings for Standard Straight-Through RS-232 Cable**

If you are using a **NULL** modem cable to connect the AC7A/B to your PC, you will need different jumper settings. See Figures 2-7 and 2-8 for more details on null modem cables. The jumper settings for a **NULL** modem cable connecting an AC7A/B to a PC are shown on the next page:

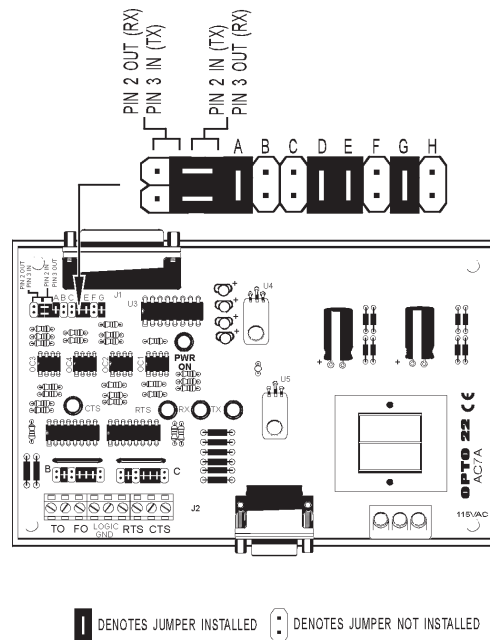


Figure 2-10: Null Modem Cable Jumper Settings

## SETTING THE AC7A/B RS-422/485 JUMPERS (GROUPS B AND C)

These two jumper groups are located above the green 9-screw-terminal RS-422/485 connector. Group B is on the left, and group C is on the right. If the AC7A/B is being used in a standard Optomux network in either repeat or multidrop mode, install the jumpers as shown below.

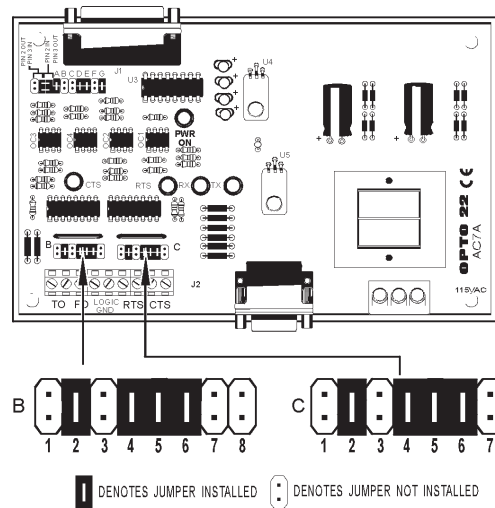


Figure 2-11: AC7A/B RS-422/485 Jumper Settings for use with Optomux Brain Boards

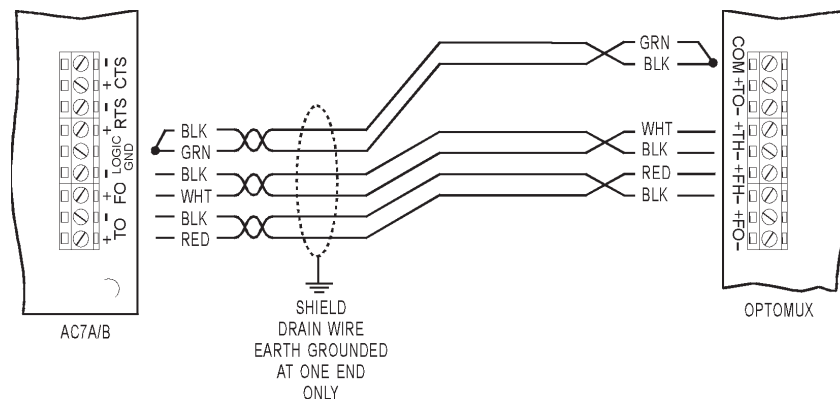
More details on these jumpers are included in later sections of this manual.

# CONNECTING THE AC7A/B TO THE OPTOMUX NETWORK

## STANDARD CONFIGURATION

For this connection, Opto 22 recommends that you use three pairs of shielded, twisted wire. This comes to a total of 6 wires in addition to the shield drain wire. All conductors should be stranded #22 or #24 gauge, with a nominal impedance of 100 ohms and a capacitance of 12.5 pF/ft.

The first pair of twisted wire connects the TO+ and TO- terminals on the AC7A/B to the FH+ and FH- terminals on the Optomux device (TO+ to FH+ and TO- to FH-). The second pair of twisted wire connects the FO+ and FO- terminals on the AC7A/B to the TH+ and TH- terminals on the Optomux equipment. The third pair of twisted wire connects the LOGIC GND terminal on the AC7A/B to the COM terminal of the Optomux device. Finally, the shield of the three pairs of twisted wire should be tied to earth ground at only one of its two ends.

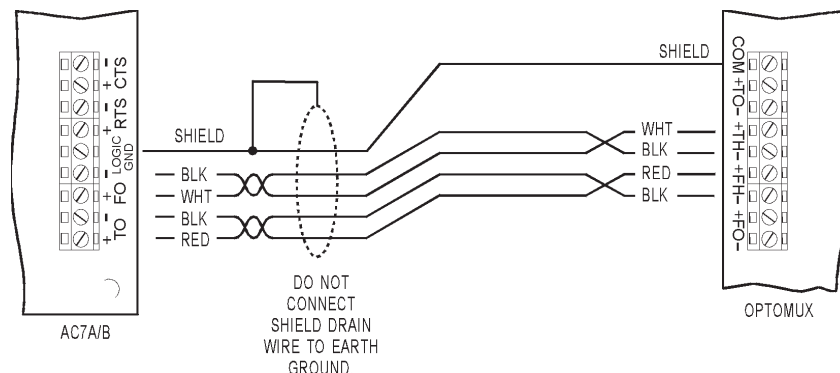


**Figure 2-12: Standard RS-422/485 Wiring from AC7A/B to Optomux Brain Board**

For details on connecting multiple Optomux brain boards to the RS-422/485 communication cable, please see the *Optomux B1 and B2* data sheet (form 463).

## ALTERNATE CONFIGURATION

A slightly less noise-immune connection may be made with a two twisted-pair shielded cable. Instead, use the shield drain wire of the cable to connect logic ground/common between the two devices. In this case, *DO NOT* connect the shield to earth ground.



**Figure 2-13: Alternate RS-422/485 Wiring from AC7A/B to Optomux Brain Board**

## ***APPLY AC POWER***

---

The AC7A/B should now be ready to use with your Optomux network. After all wiring connections are made, and jumper settings have been checked, it is time to supply AC power to the AC7A/B. The AC7A requires 115 VAC at 50–60 Hz. The AC7B uses 220VAC at 50–60 Hz. Once power has been supplied to the AC7A/B, the LED labeled PWR ON should become illuminated.

## ***COMMUNICATION LEDS***

---

The communication LEDs are labeled with respect to the RS-422/485 side of the AC7A/B.

The TX (Transmit) LED will flash when the AC7A/B is transmitting data out its RS-422/485 port (i.e., data is entering the RS-232 port and exiting the RS-422/485 port).

**TX = RS-232 → AC7A/B → RS-422/485**

The RX (Receive) LED will flash when the AC7A/B is receiving data into its RS-485 port (i.e. data is entering the RS-485 port and exiting the RS-232 port).

**RX = RS-232 ← AC7A/B ← RS-422/485**

The RTS (Request to Send) LED will turn on when the AC7A/B is requesting to transmit data out its RS-422/485 port. The RTS output tells the other RS-422/485 device that the AC7A/B would like to send data.

**RTS = AC7A/B → RS-422/485**

The CTS (Clear to Send) LED will turn on when the AC7A/B is receiving a CTS signal from another RS-422/485 device. The received CTS signal tells the AC7A/B that the other RS-422/485 device is ready to receive data. In other words, the received CTS signal gives the AC7A/B permission to transmit data out of its RS-422/485 port.

**CTS = AC7A/B ← RS-422/485**

**Note:** *The RTS and CTS lines are NOT used by Optomux, so the state of the RTS and CTS LEDs is not important when an AC7A/B is communicating with Optomux I/O devices.*



# ***INSTALLING THE AC7A/B FOR USE WITH DEVICES OTHER THAN OPTO 22'S OPTOMUX I/O***



## ***OVERVIEW***

---

The AC7A/B was originally designed specifically to make it easy to connect any device with a standard RS-232 port to Opto 22's Optomux I/O in 4 wire RS-422/485 mode. However, the AC7A/B can also be used as a general purpose, bi-directional RS-232 to RS-422/485 converter.

## ***EQUIPMENT REQUIRED FOR INSTALLATION***

---

- Medium size flat-blade screwdriver
- Wire stripper
- Variety of color-coded wires and cables:
  - #22 or #24 gauge twisted-pair cable for communication cables
  - #18 gauge for power connections.

## ***MOUNTING THE AC7A/B***

---

The AC7A/B adapter card may be mounted in any position on any flat surface. The AC7A/B is supplied with 3/4" standoffs. All of the standoffs should be secured using #6 mounting hardware to provide maximum physical strength. Sufficient space should be left around the AC7A/B for serial communication cables and for power wiring. Figure 3-1 shows the dimensions of the AC7A/B adapter card.

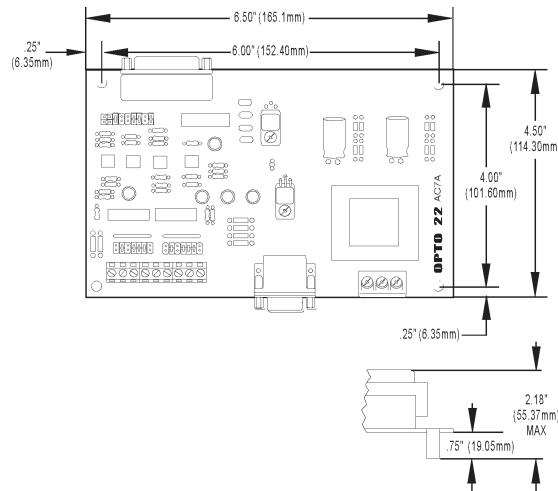


Figure 3-1: AC7A/B Card Dimensions

## CONNECTING AC POWER TO THE AC7A/B

**Caution: Make sure that power is OFF** while making or removing all connections to the AC7A/B and other devices. For safety purposes, a plastic insulating cover is provided for the power terminal block and should be installed after power wiring is completed.

The AC7A/B has a terminal strip with three screw terminals for AC power. The AC power that is supplied to the AC7A/B should have three wires, two for AC power and one for earth ground (usually colored green). Connect the wire for earth ground to the center screw terminal which is labeled GND. Connect the other two wires to the terminals marked AC, one wire per terminal. The polarity of the AC power wires with respect to the AC screw terminals on the power connector of the AC7A/B does not matter.

If using a standard, 3-conductor power cord with a three-pronged plug, it should be at least #18 gauge wires or larger. On one end should be the three-pronged plug; the other should have three wires with approximately 1/4" (6mm) of insulation stripped off the end of each wire. Find the wire that corresponds to earth ground (usually colored green) and connect this to the terminal labeled GND. You may determine the ground wire by using an ohmmeter and testing for continuity with the ground pin on the plug. The other two wires should be connected to the terminals marked AC, one wire per terminal. The polarity of the AC power wires with respect to the screw terminals marked AC on the AC7A/B does not matter.

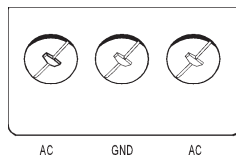


Figure 3-2: Connector Terminal

## CONNECTING THE AC7A/B TO A PC OR OTHER RS-232 DEVICE

A standard RS-232 serial cable may be used to connect the AC7A/B adapter card to the PC. One end of the RS-232 cable must have a male 25-pin (DB-25) connector for the AC7A/B. The other end of the cable is for the PC, and will most likely need either a 9-pin (DB-9) female connector, or a 25-pin (DB-25) female connector, depending on your computer. Figure 3-3 shows the connections between a 25-pin RS-232 serial port and the AC7A/B using a standard straight-through cable. Figure 3-4 shows the connections between an AC7A/B adapter card and a 9-pin RS-232 serial port using a standard straight-through cable.

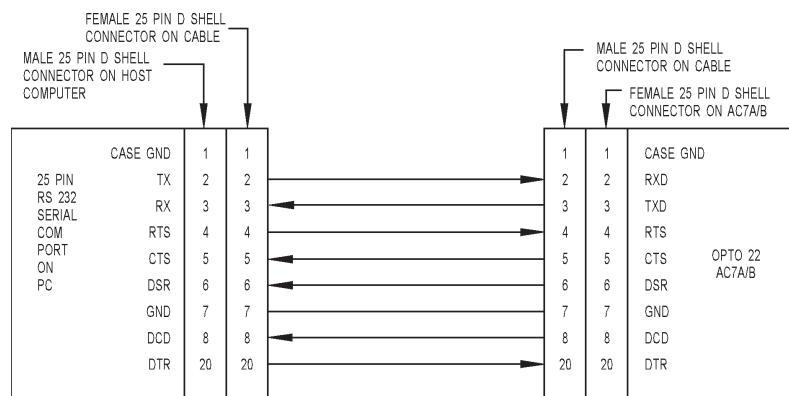


Figure 3-3: Standard Straight-Through 25-Pin to 25-Pin RS-232 Cable

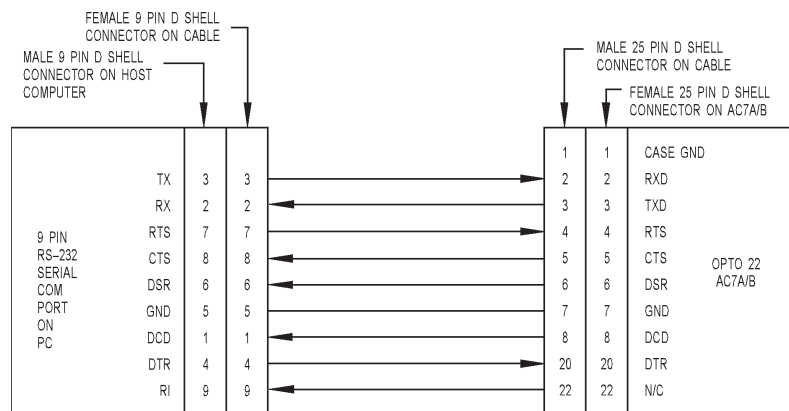
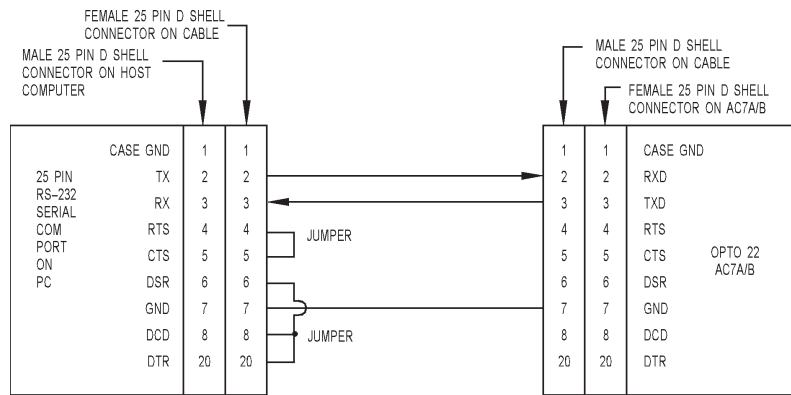


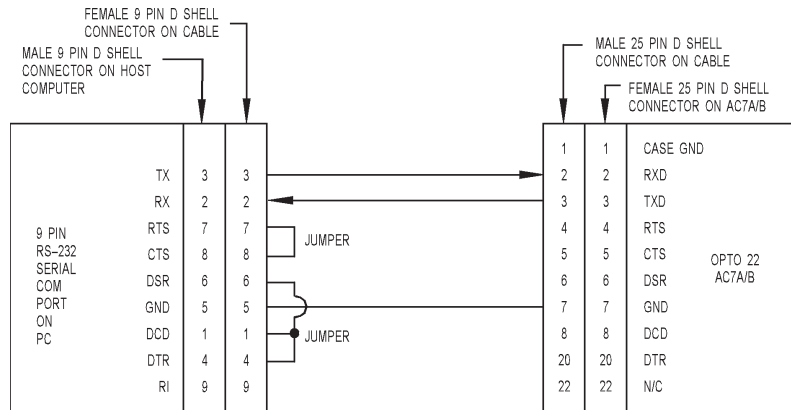
Figure 3-4: Standard Straight-Through 9-Pin to 25-Pin RS-232 Cable

It is also possible to make your own cable for connections between the AC7A/B and an RS-232 device. The only connections that are absolutely necessary are transmit and receive (RS-232 pins 2 and 3) and signal ground, which is pin 7 of standard 25-pin connectors. Ground is usually pin 5 on 9-pin RS-232 connectors. (Note: the 9-pin connector on the AC7A/B adapter card is for RS-422/485, not RS-232.)

This sections applies only to the 25-pin [DB-25] RS-232 connection on the AC7A/B adapter card.)

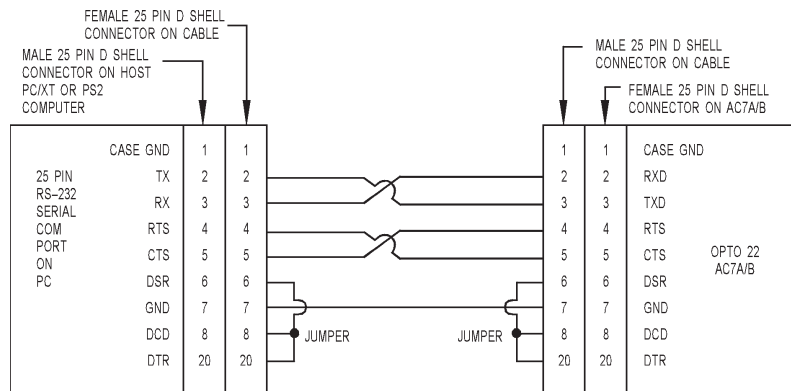


**Figure 3-5: 25-Pin to 25-Pin, 3-Wire RS-232 Cable (made by user)**

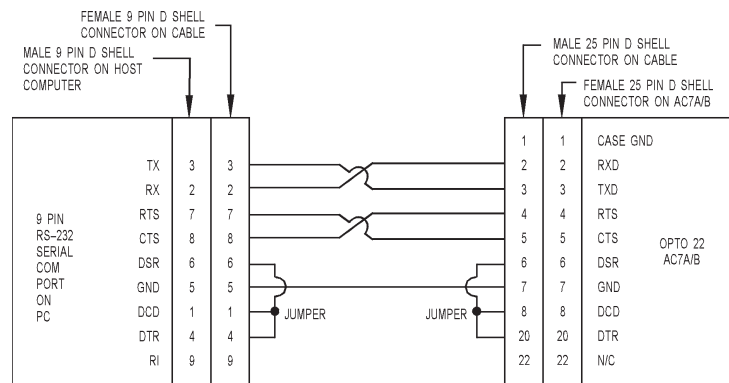


**Figure 3-6: 9-Pin to 25-Pin, 3-Wire RS-232 Cable (made by user)**

**Note:** Some serial cables that look like standard straight through cables are actually null modem cables. The wiring diagram for a **NULL** modem cable is shown below:



**Figure 3-7: 25-Pin to 25-Pin Null Modem Cable Diagram**



**Figure 3-8: 9-Pin to 25-Pin Null Modem Cable Diagram**

To determine whether you have a null-modem or standard cable, perform the following tests:

**If you have a cable with 25-pin connectors at both ends**, then test the cable for electrical continuity between pin 2 on one end of the cable and pin 2 on the other end. These two pins are tied together on a standard 25-pin to 25-pin straight-through cable. In a 25-pin to 25-pin null-modem cable, pin 2 of one end is tied to pin 3 of the other end.

**If you have a cable with a 25-pin connector at one end, and a 9-pin on the other end**, then test the cable for electrical continuity between pin 2 on one end of the cable and pin 3 on the other end. These two pins are tied together on a standard 25-pin to 9-pin straight-through cable. In a 25-pin to 9-pin null-modem cable, pin 2 of one end is tied to pin 2 of the other end.

Aside from transmit, receive, and ground, other RS-232 signals are sometimes used with third-party equipment. Some of the other signals that might be used are shown in the table below. Connections should be made if your equipment requires them. More information on the functions of these signals is given in Chapter 4.

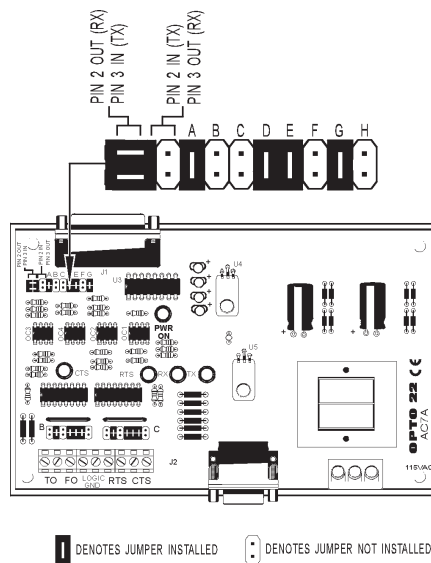
\* The terms "Transmit" and "Receive" for these two pins both apply from the computer's point of view.

## ***SETTING THE AC7A/B RS-232 JUMPERS (FIRST GROUP - NEAR THE 25-PIN RS-232 CONNECTOR)***

The six pins to the left of the jumpers labeled A through H located near the RS-232 connector on the AC7A/B determine which pin of the RS-232 port on the AC7A/B is used for transmitting data and which pin is used for receiving.

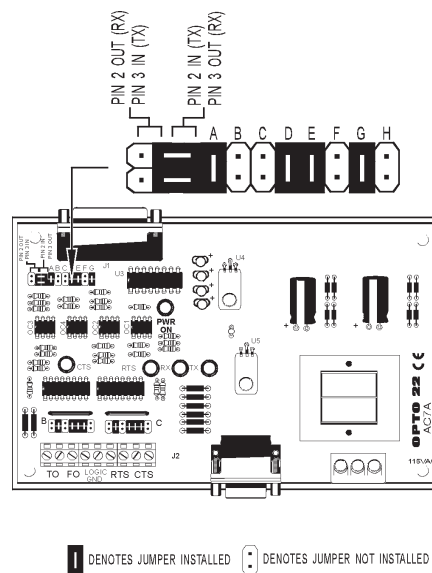
**The AC7A/B factory default configuration uses pin 3 of the RS-232 port to receive data and pin 2 to transmit data.** Moving the jumpers to the opposite position causes pin 2 on the AC7A/B RS-232 port to receive data, and pin 3 on the AC7A/B RS-232 port to transmit data. The jumpers may need to be moved to the other position, depending on whether or not you are using a standard straight-through cable, or a null modem cable. The jumpers may also need to be moved depending on what type of device is being connected to the AC7A/B. For instance, a computer that has a DTE RS-232 port would need the jumpers in one position, whereas a modem that has a DCE RS-232 port would need the jumpers in the opposite position. Moving the jumpers simply changes which pin (2 or 3) on the AC7A/B receives data and which pin (2 or 3) on the AC7A/B transmits data.

For a **standard straight-through RS-232 cable** connected to a PC (a DTE RS-232 port), set these jumpers as shown below:



**Figure 3-9: Jumper Settings for Standard Straight-Through RS-232 Cable**

If you are using a **NULL** modem cable to connect the AC7A/B to your PC, you will need different jumper settings. The jumper settings for a **NULL** modem cable connecting an AC7A/B to a PC (a DTE RS-232 port) are shown below:



**Figure 3-10: Jumper Settings for use with an RS-232 Null Modem Cable**

More detailed information about these jumpers is available in Chapter 4.

## RS-232 HANDSHAKING SIGNALS FOR HARDWARE FLOW CONTROL

If the RS-232 and RS-422/485 devices connected to the AC7A/B adapter card DO NOT need hardware flow control, you may use the factory defaults for jumpers A through H and ignore this section.

If the RS-232 and/or RS-422/485 devices connected to the AC7A/B adapter card require hardware flow control, then please read the following material.

Though the AC7A/B does have a DB-25 connector (with 25 pins) on the RS-232 side, only three pins are used for carrying data: transmit, receive, and common (ground). The others pins are primarily used for "handshaking" or flow control, to manage or coordinate the flow of communication. Such signals may or may not be needed by the other devices that you are connecting to the AC7A/B adapter card. They are not needed by the AC7A/B. You may need to jumper various pins to make the other equipment communicates properly with the AC7A/B.

Below are several examples of different applications that require different wiring and/or jumper settings:

### **If you are using a three-wire (TX, RX, and GND) RS-232 cable, and the RS-232 device requires hardware flow control, but the RS-422/485 device does not:**

Such a situation can arise if you are connecting a modem to an Optomux brain board with the AC7A/B. If this is the case, physically connect CTS to RTS on the connector of the RS-232 device. Also, jumper together DSR, DCD, and DTR on the connector of the RS-232 device. Install jumpers A, D, E, and G on the AC7A/B. Remove jumpers B, C, F, and H on the AC7A/B.

### **If you are using a three-wire (TX, RX, and GND) RS-232 cable, and the RS-232 device does not require hardware flow control, but the RS-422/485 does:**

Physically connect CTS+ to RTS+ and connect CTS- to RTS- on the connector of the RS-485 device. Also, jumper together DSR, DCD, and DTR on the connector of the RS-232 device. Install jumpers A, D, E, and G on the AC7A/B. Remove jumpers B, C, F, and H on the AC7A/B.

### **If you are using a three-wire (TX, RX, and GND) RS-232 cable, and both the RS-232 and RS-422/485 devices require hardware flow control:**

First connect CTS+ to RTS+ and connect CTS- to RTS- on the connector of the RS-485 device. Also physically connect CTS to RTS on the connector of the RS-232 device. Next, jumper together DSR, DCD, and DTR on the connector of the RS-232 device. Install jumpers A, D, E, and G on the AC7A/B. Remove jumpers B, C, F, and H on the AC7A/B. This should work, although your particular equipment may require different settings.

### **If you are using a standard, store-bought serial or null-modem RS-232 cable, and the RS-232 device requires hardware flow control, but the RS-422/485 device does not:**

Install jumpers A, B, C, D, G, and H on the AC7A/B. Remove jumpers E and F on the AC7A/B.

### **If you are using a standard, store-bought serial or null-modem RS-232 cable, and the RS-232 device does not require hardware flow control, but the RS-422/485 device does:**

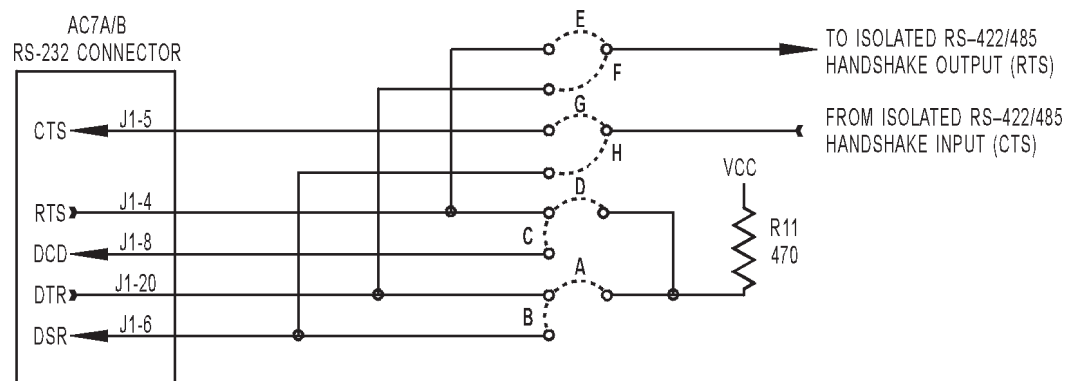
Install jumpers A, B, F, and H on the AC7A/B, and make sure the RTS ± and CTS ± lines are connected between the AC7A and the RS-422/485 device. Remove jumpers C, D, E, and G on the AC7A/B.

**If you are using a standard, store-bought serial or null-modem RS-232 cable, and both the RS-232 and RS-422/485 devices require hardware flow control:**

Install jumpers E and G on the AC7A/B, and make sure the RTS ± and CTS ± lines are connected between the AC7A and the RS-422/485 device. Remove jumpers A, B, C, D, F, and H on the AC7A/B. This should work, although your particular equipment may require different settings.

**If your particular application does not fit into any of the above categories:**

The following schematic may help you design a custom configuration. The jumpers set various leads high, or guide the signals from the RS-232 port to the appropriate pins on the RS-422/485 port. You may need to consult an RS-232 or RS-422/485 reference book.



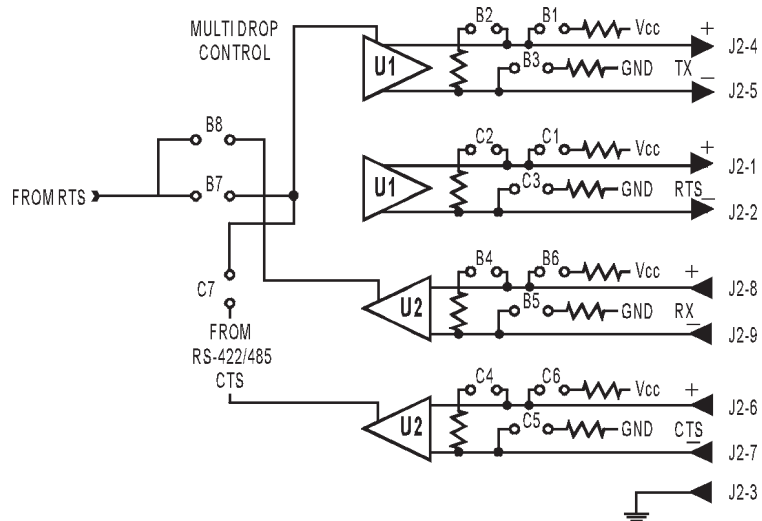
**Figure 3-11: AC7A/B Jumpers A through H Schematic**

## ***SETTING THE AC7A/B RS-422/485 JUMPERS (GROUPS B AND C)***

These two jumper groups are located above the green 9-screw-terminal RS-422/485 connector. Group B is on the left, and group C is on the right.

- a. Each RS-422/485 twisted pair communication cable must be terminated at both ends of the communication link only. This can be done by installing jumpers B2 (for TO or Transmit) and B4 (for FO or receive) on the AC7A/B end. The other end of the RS-422/485 cable should be terminated with a 220 Ohm resistor installed between the + and - terminals of each line.
- b. In addition to terminating the RS-422/485 lines, as described above, each RS-422/485 twisted pair should also be biased at one end only. Biasing is done with pull up and pull down resistors. This can be done with jumpers B1 and B3 (for TO or transmit) and B5 and B6 (for FO or receive) on the AC7A/B end. The purpose of biasing is to hold the communication lines at a known intermediate voltage state when the lines are not being driven to a high or low state by one of the devices on the communication line.





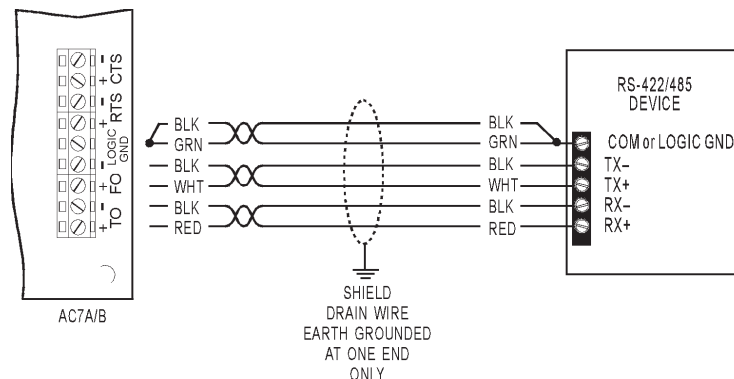
**Figure 3-12: Group B and C RS-422/485 Jumper Schematic**

More details on these jumpers is included in later sections of this manual.

## CONNECTING THE AC7A/B TO AN RS-422/485 DEVICE

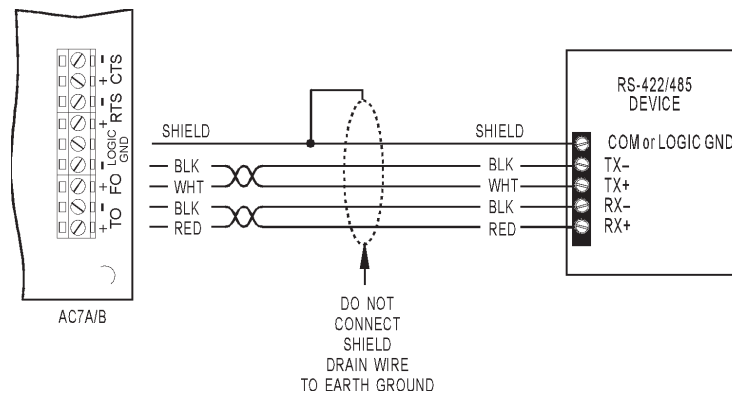
For this connection, Opto 22 recommends the use of three pairs of shielded, twisted wire (a total of six wires). All conductors should be stranded #22 or #24 gauge, with a nominal impedance of 100 ohms and a capacitance of 12.5 pF/ft.

The first pair of wires is used for the transmit line. The second pair of wires is used for the receive line. The third pair of wires is used to connect the LOGIC GND of the AC7A/B to the COM terminal of the RS-485 device. Finally, the shield of the three pairs of twisted wire should be tied to earth ground at only one end of the shield.



**Figure 3-13: RS-422/485 Cabling Diagram**

A slightly less noise-immune connection may be made with a two twisted-pair shielded cable. Instead, use the shield drain wire of the cable to connect logic ground/common between the two devices. In this case, *DO NOT* connect the shield to earth ground.



**Figure 3-14: RS-422/485 Cabling Diagram (alternative, less noise immune)**

**General guidelines for using an AC7A/B with other RS-422/485 devices:**

- a. The RS-422/485 screw terminals on the AC7A/B are labeled TO+, TO-, FO+, and FO-. This labeling convention is for Opto 22's Optomux I/O. For use with devices other than Opto 22's Optomux I/O, the following convention applies to the RS-485 port of the AC7A/B

**TO+ = Transmit+**

**FO+ = Receive+**

**TO- = Transmit-**

**FO- = Receive-**

- b. The RTS and CTS terminals are used for hardware handshaking (flow control). RTS± are outputs from the AC7A/B. CTS± are inputs into the AC7A/B.
- c. The AC7A/B was designed to communicate in 4-wire RS-422/485 mode. In the 4-wire mode uses two twisted-pairs of wiring (four conductors total) are used for communication. In 4-wire mode, one twisted-pair of wires is used for the transmit signal and the other twisted pair of wires is used for the receive signal. One additional pair (pair #3) of wires is used to connect the LOGIC GND of the AC7A/B to the COM terminal of the RS-422/485 device.
- d. In most applications, the AC7A/B can also be used in 2-wire RS-485 mode. In the 2-wire mode uses one twisted-pair of wiring (two conductors total) is used for communication. In 2-wire mode, the same twisted-pair of wires is used for the transmit signal and the receive signal. One additional pair (pair #2) of wires is used to connect the LOGIC GND of the AC7A/B to the COM terminal of the RS-485 device. To use the AC7A/B in two wire mode, see the section titled Two-Wire RS-485 Mode (page 25).

---

## APPLYING AC POWER

---

The AC7A/B should now be ready to use. After all wiring connections are made, and jumper settings have been checked, it is time to supply AC power to the AC7A/B. The AC7A requires 115 VAC at 50-60 Hz. The AC7B uses 220VAC at 50-60 Hz. Once power has been supplied to the AC7A/B, the LED labeled PWR ON should become illuminated.

---

## COMMUNICATION LEADS

---

The communication LEDs are labeled with respect to the RS-422/485 side of the AC7A/B.

The TX (Transmit) LED will flash when the AC7A/B is transmitting data through its RS-422/485 port (i.e., data is entering the RS-232 port and exiting the RS-422/485 port).

**TX = RS-232 → AC7A/B → RS-422/485**

The RX (Receive) LED will flash when the AC7A/B is receiving data to its RS-422/485 port (i.e., data is entering the RS-232 port and exiting the RS-422/485 port).

**RX = RS-232 ← AC7A/B ← RS-422/485**

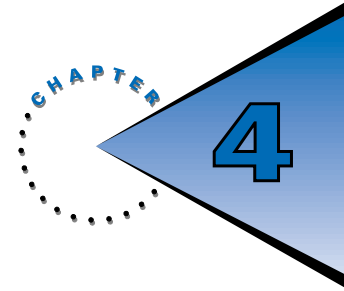
The RTS (Request to Send) LED will turn on when the AC7A/B is requesting to transmit data through its RS-422/485 port. The RTS output tells the other RS-485 device that the AC7A/B would like to send data.

**RTS = AC7A/B → RS-422/485**

The CTS (Clear to Send) LED will turn on when the AC7A/B is receiving a CTS signal from another RS-422/485 device. The received CTS signal tells the AC7A/B that the other RS-422/485 device is ready to receive data. In other words, the received CTS signal gives the AC7A/B permission to transmit data out of its RS-422/485 port.

**CTS = AC7A/B ← RS-422/485**

# ADDITIONAL TECHNICAL INFORMATION



## GENERAL NOTES

---

- a. The communication LEDs are labeled with respect to the RS-422/485 side of the AC7A/B.

The TX (Transmit) LED will flash when the AC7A/B is transmitting data through its RS-422/485 port (i.e., data is entering the RS-232 port and exiting the RS-422/485 port).

**TX = RS-232 → AC7A/B → RS-422/485**

The RX (Receive) LED will flash when the AC7A/B is receiving data into its RS-422/485 port (i.e., data is entering the RS-485 port and exiting the RS-232 port).

**RX = RS-232 ← AC7A/B ← RS-422/485**

The RTS (Request to Send) LED will turn on when the AC7A/B is requesting to transmit data out its RS-422/485 port. The RTS output tells the other RS-422/485 device that the AC7A/B would like to send data.

**RTS = AC7A/B → RS-422/485**

The CTS (Clear to Send) LED will turn on when the AC7A/B is receiving a CTS signal from another RS-422/485 device. The received CTS signal tells the AC7A/B that the other RS-422/485 device is ready to receive data. In other words, the received CTS signal gives the AC7A/B permission to transmit data out of its RS-422/485 port.

**CTS = AC7A/B ← RS-422/485**

- b.  $TO_{\pm}$  and  $RTS_{\pm}$  are outputs from the AC7A/B.
- c.  $FO_{\pm}$  and  $CTS_{\pm}$  are inputs into the AC7A/B.
- d.  $TO$  and  $FO$  are used for data.  $RTS$  and  $CTS$  are used for handshaking.
- e. Logic GND is an electrical reference point. While not absolutely essential, it is used to connect the DC common of the AC7A/B power supply to the DC common of the other device's power supply. This is used to equalize (voltage) differences between the two devices when each device has an isolated floating power supply.

## TWO-WIRE RS-485 MODE

A few minor modifications must be made if you are using the AC7A/B in 2-wire mode.

First, you will probably have to make your own custom RS-232 cable from the AC7A/B to the PC. This is to ensure that DTR (pin 20) on the AC7A/B's RS-232 connector is not connected. If you are using a 25-pin port on the PC, then you'll need to make these three connections:

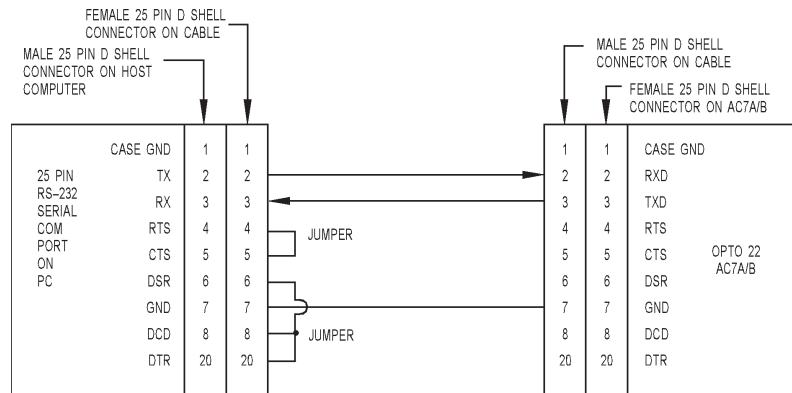


Figure 4-1: 25-Pin RS-232 Cable for AC7A/B RS-485 2-Wire Mode

If you are using a 9-pin serial port on the PC, then you will need to wire these connections:

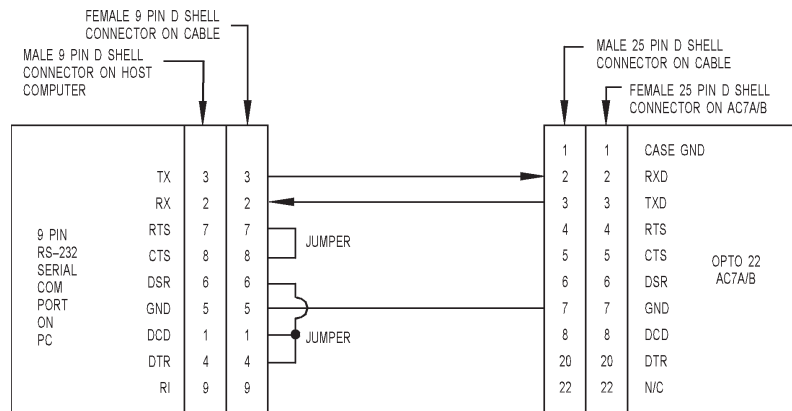
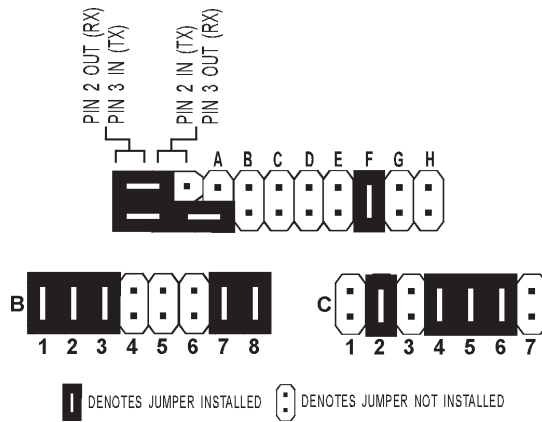


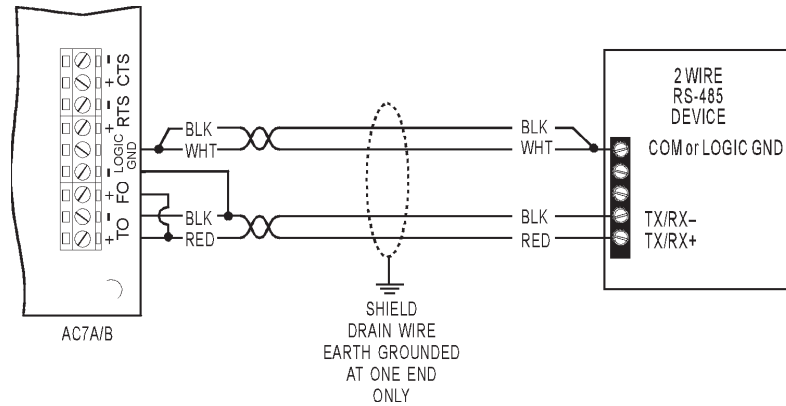
Figure 4-2: 9-Pin RS-232 Cable for AC7A/B RS-485 2-Wire Mode

Second, install the three sets of jumpers on the AC7A/B as shown below. The shaded areas indicate where jumpers need to be placed.



**Figure 4-3: Three Sets of AC7A/B Jumpers**

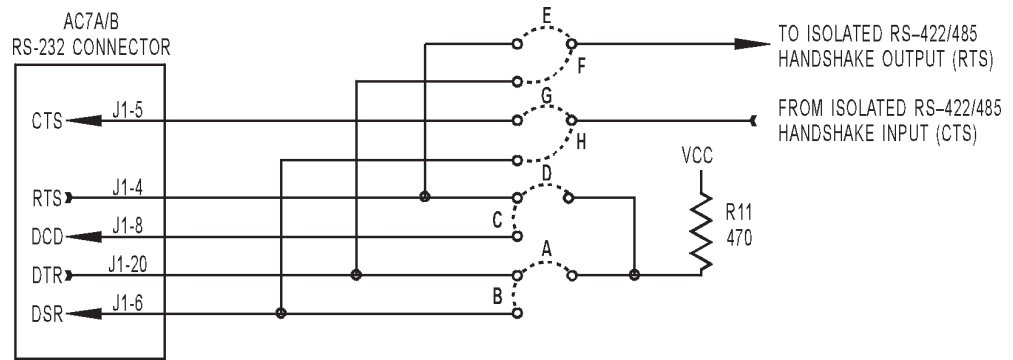
Finally, connect FO+ to TO+, and FO- to TO- on the AC7A/B as shown below.



**Figure 4-4: Connecting the AC7A/B to the 2-Wire RS-485 Device**

## COMMONLY USED RS-232 SIGNALS

It is possible to effectively rewire certain pins of the RS-232 connector on the AC7A/B with the group of jumpers labeled A through H. These pins carry hardware handshaking signals which are commonly used to coordinate communication flow.



**Figure 4-5: AC7A/B Jumpers A through H Schematic**

RS-232 is a simple communication scheme that supports one device at each end of the RS-232 cable (two devices total). In general, one device is designated DTE (data terminal equipment) and the other is designated DCE (data communication equipment). For example, a computer is a DTE device, and a modem is the DCE device. The AC7A/B functions as DCE when connected to a computer. For the purposes of this section, the words “computer” and “modem” will be used in place of “DTE” and “DCE” respectively.

The standard connector used with RS-232 is the 25-pin D-shaped (DB-25) connector that is used by the AC7A/B. A 9-pin connector (DB-9), which was first used on the IBM PC/AT, is also found on many computers. The most commonly used RS-232 signals are given below, along with their pin assignments.

\* *The terms “Transmit” and “Receive” for these two pins both apply from the computer’s point of view.*

**RTS** and **DTR** are both sent by the computer. DTR merely indicates that the computer is powered up and able to communicate with the modem. RTS is sent by the computer when the computer wants to send data.

**CTS**, **DSR**, and **DCD** are signals sent by the modem (and therefore are inputs to the computer). DCD is high when the modem has detected analog signals on its telephone line port that are carrying digital data. DSR is similar to DTR — it indicates to the computer that the modem is in a state of readiness.

**CTS** is a response to the RTS signal. The modem realizes that the computer wants to send data when the modem’s RTS input goes high. Then the modem sends its CTS output high when the modem is ready to receive the computer’s data. Only when the computer senses that its CTS input is high will it start sending data.

While this system of handshaking signals works well, it can become troublesome when the communication is not between a computer and a modem. Oftentimes, one piece of equipment may not need nor use these hardware flow control signals, while the other piece of equipment requires hardware flow control. The device that expects hardware handshaking signals will not communicate until it receives the appropriate signals. To resolve such problems, appropriate pins may be wired together to trick a device into thinking that its counterpart is sending the required handshaking signals. One method is to wire RTS to CTS, and wire together DSR, DCD, and DTR on the devices' RS-232 serial port. Connecting RTS to CTS tells the computer that it can send data whenever it wants to. Connecting together DSR, DCD, and DTR means that the computer or modem will always think that the other device is online and ready to communicate.

### **USING PROTECTIVE GROUND ON AC7A/B**

Pin 1, protective ground on the 25-pin connector, can be tied to the terminal marked GND on the AC7A/B adapter card by installing the jumper labeled JX. This is not normally used. This is only necessary if protective ground is being used and is not grounded on the host computer end. Newer AC7A/Bs do not have a JX jumper.

## ***BIASING AND TERMINATING RS-422/485***

---

RS-485 uses two wires for each data line. The data signal is transmitted as the difference in voltage between the two wires that make up a single data line. Which of these two wires has the higher voltage determines whether the wires carry a DIGITAL ON or DIGITAL OFF. Unlike RS-232, RS-485 allows more than one transmitter and/or receiver on a single data line. These two characteristics are the reason that biasing and termination are required on an RS-485 communication line.

**Note:** RS-422 is very similar to RS-485. The key difference is that RS-422 allows one (and only one) transmitter and multiple receivers on a single data line.

The RS-485 network is composed of two wires that comprise a single, main transmission "bus" or "trunk" line, with transmitters and receivers connected along the central line. Terminating resistors are needed at the two ends of this main line. Usually, this is done at the devices located at the physical ends of the line. Since the AC7A/B is usually located at the beginning or end of an RS-485 transmission line, the AC7A/B is usually the location for one of the termination resistors. However, a resistor doesn't physically have to be added, because the AC7A/B contains terminating resistors. Installing the appropriate jumper (B2, B4, C2, or C4) on the AC7A/B connects the termination resistor to the transmission line.

Sometimes the AC7A/B is placed in the middle of the RS-485 trunk, in which case the terminating jumper should not be installed.

Because the outputs of more than one RS-485 transmitter may be tied together on the communication line, they cannot all be actively driving the line at the same time. Thus, no more than one transmitter is actually sending signals at any given time; the others in a sense electrically disconnect from the network (though they still represent a load on whoever is driving the network). This condition is called disabling the transmitter, or disabling the driver. The enabling/disabling of the transmitter (TO) on the AC7A/B can be configured to be controlled by RTS or CTS.

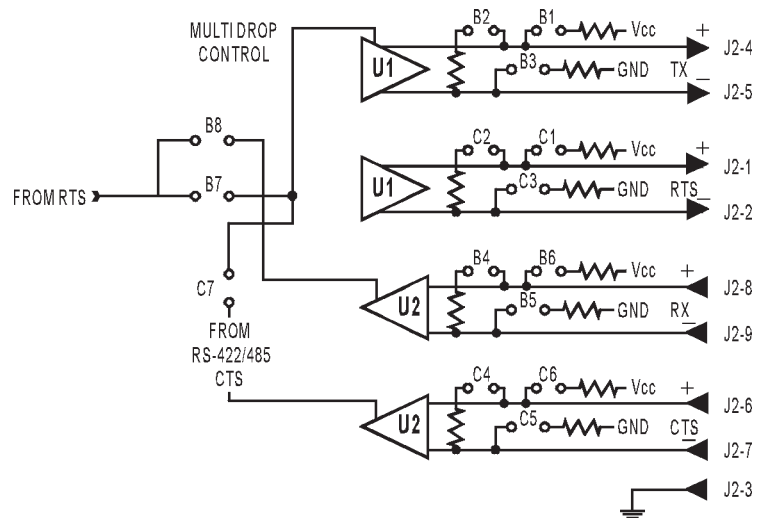


If none of the RS-485 transmitters need to talk, they may all be disabled. In this case, the communication line is floating because it is not being driven to some definite HIGH or LOW state. To resolve this, **biasing** resistors are needed to put the transmission line in a known, predefined state. This prevents electrical noise from causing the communication line to float HIGH or LOW when the RS-485 line is idle. Otherwise, an RS-485 receiver may incorrectly interpret the noise on the communication line as data. Since the transmission line is actually made up of two wires, one resistor for each wire is needed. However, only one pair of biasing resistors may be placed on an RS-485 network. Jumpers are provided on the AC7A/B to connect the biasing resistors to the RS-485 communication lines. If biasing is already accomplished at some other point on the RS-485 line, then the biasing resistor jumpers should be removed on the AC7A/B.

In summary, an RS-485 communication line must be terminated at both ends by having a terminating resistor placed across the pair of wires that make up a single data line. In addition, the RS-485 data line must be biased at one location only.

### COMMUNICATION JUMPERS

Group B and C jumpers configure the RS-422/485 lines. These determine the biasing and termination of the wires and they also control the enabling of the RS-422/485 transmitter (TO) and the RS-422/485 receiver (FO).



**Figure 4-6: Communication Jumpers**

As shown in the diagram above, B1, B3, C1, C3, B5, B6, C5, and C6 connect the RS-422/485 lines to biasing resistors. B2, C2, B4, and C4 insert terminating resistors across the pairs of wires used in each RS-422/485 line. B7, C7, and B8 control whether the TO driver and FO receiver can be enabled/disabled by RTS or CTS. For more information concerning RS-422/485 and the need for biasing and terminating, see Biasing and Terminating RS-422/485 on page 29.

## TROUBLESHOOTING

---

The AC7A/B is a simple pass-through communication converter. Troubleshooting communication problems with the AC7A/B is simple, as long as an organized methodical approach is used. The following sequential procedure is recommended:

- a.** Verify that the PWR ON LED is illuminated. If yes, go on to step "b." If the PWR ON LED is not illuminated, then use a voltmeter to verify that there is proper AC voltage across the power terminals marked "AC." The AC7A should have 115 VAC across the power terminals marked "AC." The AC7B should have 220 VAC across the power terminals marked "AC." The AC7A or AC7B will not function correctly unless the proper AC voltage is supplied to it.
- b.** Verify that an RS-232 cable is connected from a computer to the 25-pin (DB25) RS-232 connector on the AC7A/B. For more details on RS-232 cabling to an AC7A/B, see Chapter 3 of this manual. Make sure that the RS-232 cable from the computer to the 25-pin (DB25) RS-232 connector on the AC7A/B exactly matches the wiring diagrams of one of the cables shown in Section 3-2 of this manual.
- c.** Send data into the AC7A/B's RS-232 port. Verify that the AC7A/B's TX LED is flashing when data is entering the AC7A/B's RS-232 port. It may be necessary to slow down the RS-232 baud rate to make the LEDs flash slower, which will make the LEDs easier to see. If the TX LED does flash, then go on to step "d." If the TX LED is not flashing, it may be because the RS-232 jumpers are incorrect for the type of cable being used. See Chapter 3 of this manual for detailed instructions on setting the AC7A/B RS-232 jumpers. If the TX LED is flashing, this means that RS-232 data is being received by the AC7A/B and re-transmitted out the RS-485 (TO $\pm$ ) terminals.
- d.** For testing purposes, temporarily disconnect any RS-422/485 wiring from the AC7A/B. Next, temporarily connect the TO+ terminal to the FO+ terminal. Then temporarily connect the TO- terminal to the FO- terminal. This will create a loop back cable on the AC7A/B's RS-422/485 port, which will take the data going out of the AC7A/B's RS-422/485 transmit lines and send it back into the AC7A/B's RS-422/485 receive lines. Now send data from a computer to the AC7A/B's RS-232 port, and verify that both the AC7A/B's TX and RX LEDs are flashing when data is entering the AC7A/B's RS-232 port. It may be necessary to slow down the RS-232 baud rate to make the LEDs flash slower, which will make the LEDs easier to see. If the TX LED is flashing, this means that RS-232 data is being received by the AC7A/B and re-transmitted out the RS-422/485 transmit (TO $\pm$ ) terminals. But because of the RS-422/485 loop back cable, the data is looped back from the RS-422/485 transmit (TO $\pm$ ) terminals into the RS-422/485 (FO $\pm$ ) receive terminals, and finally sent back to the computer through the AC7A/B's RS-232 port.
- e.** If a software program for a computer such as Windows-Terminal or HyperTerminal is available, use it to send data out of the computer's RS-232 port to the AC7A/B. If the RS-422/485 loop back cable is still connected as in step "d" above, then whatever is typed on the keyboard of the computer should be displayed on the computer's monitor. If keys are being pressed on the computer's keyboard, and the AC7A/B's TX and RX LEDs are flashing, but nothing is being displayed on the computer's monitor, then the most likely reasons are that (1) the terminal program or the operating system is configured for the wrong interrupt (IRQ) line, or (2) there is an interrupt conflict between the serial port and another device in the computer. Either or both of these conditions may need to be corrected. If data that is typed on the keyboard of the computer is displayed on the computer's monitor, then the AC7A/B is functioning correctly.

**Note:** Ensure that RS-422/485 cables are twisted-pair cables.

---

## ***GLOSSARY OF TERMS***

---

**CTS** – an abbreviation for Clear to Send. CTS is a response to the RTS signal. CTS is a signal received by the computer. Basically, the CTS signal means that the other device received the Request to Send from the computer, and now the other device is sending CTS to give permission to the computer to begin sending data.

**DCD** – an abbreviation for Data Carrier Detect. DCD is received by a computer from a modem. The modem sends a DCD output when it has detected an analog carrier signal on its telephone line port which is carrying digital data. DCD is an indication that the modem has a valid data connection with another modem at the other end of the telephone line.

**DCE** – an abbreviation for Data Communications Equipment. This term is used to describe equipment that does not create or use data, but instead only transports data. An example of Data Communication Equipment (DCE) is a modem, which transports data over telephone lines. DCE devices usually have a female gender DB25 RS-232 connector on them. For ease in cabling, DCE devices are designed to connect with a straight-through RS-232 cable to DTE devices.

**DSR** – an abbreviation for Data Set Ready. DSR indicates to the computer that the modem is in a state of readiness.

**DTE** – an abbreviation for Data Terminal Equipment. This term is used to describe equipment that creates or uses data. An example of Data Terminal Equipment (DTE) is a computer. DTE devices usually have a male gender DB25 RS-232 connector on them. For ease in cabling, DTE devices are designed to connect with a straight-through RS-232 cable to DCE devices. If two DTE devices were to be connected together, an RS-232 null modem cable would have to be used.

**DTR** – an abbreviation for Data Terminal Ready. This is an output from the computer and it means that the computer is powered up, and ready to communicate with another device.

**GND** – an abbreviation for Ground or Logic Ground.

**RD** – an abbreviation for Receive Data. Also sometimes shown as RX or RXD. This is the pin on a serial communication port where data is received from other devices.

**RS-232** – a computer interface standard that supports one device at each end of the RS-232 cable (two devices total). RS-232 in its simplest form uses three wires: a transmit wire, a receive wire, and a signal ground wire. Note that the same ground is used for transmit and receive.

**RS-422** – a computer interface standard that supports a single transmitter and one or more receivers on a single twisted-pair cable. RS-422 uses a twisted-pair cable and both wires are isolated from ground. The data signal is represented as the difference in voltage between the two wires, instead of being referenced to ground. The fact that RS-422 is differential-based, instead of ground-based, makes it much more immune to noise, and allows longer cable lengths.

**RS-485** – a computer interface standard that supports multiple transmitters and multiple receivers on a single twisted-pair cable. RS-485 uses a twisted pair cable and both wires are isolated from ground. The data signal is represented as the difference in voltage between the two wires, instead of being referenced to ground. The fact that RS-485 is differential-based, instead of ground-based, makes it much more immune to noise, and allows longer cable lengths.

**RTS**—an abbreviation for Request to Send. RTS is a signal sent by the computer to tell the other device that the computer wants to send data to the other device.

**TD**—an abbreviation for Transmit Data. Also sometimes shown as TX or TXD. This is the pin on a serial communication port where data is sent out to other devices.

## ***RS-422/485 CABLE SPECIFICATIONS***

---

The following cables are recommended for RS-422/485 serial communications. Although you may elect to use other cables, keep in mind that low capacitance (less than 15 pF/ft.) is important for high-speed digital communication links. The cables listed below are all 24-gauge, 7x32 stranded, with 100-ohm nominal impedance and a capacitance of 12.5 pF/ft.

Select from the following four-, three-, and two-pair cables, depending on your application needs. All will yield satisfactory results. It is recommended that you choose a cable with one more pair than your application requires. Use one of the extra wires, rather than the shield, for the common.

### **Four-Pair:**

- Belden P/N 8104 (with overall shield)
- Belden P/N 9728 (individually shielded)
- Belden P/N 8164 (individually shielded with overall shield)
- Manhattan P/N M3477 (individually shielded with overall shield)
- Manhattan P/N M39251 (individually shielded with overall shield)

### **Three-Pair:**

- Belden P/N 8103 (with overall shield)
- Belden P/N 9730 (individually shielded)
- Belden P/N 8163 (individually shielded with overall shield)
- Manhattan P/N M3476 (individually shielded with overall shield)
- Manhattan P/N M39250 (individually shielded with overall shield)

### **Two-Pair:**

- Belden P/N 8102 (with overall shield)
- Belden P/N 9729 (individually shielded)
- Belden P/N 8162 (individually shielded with overall shield)
- Manhattan P/N M3475 (individually shielded with overall shield)
- Manhattan P/N M39249 (individually shielded with overall shield)

# APPENDIX A

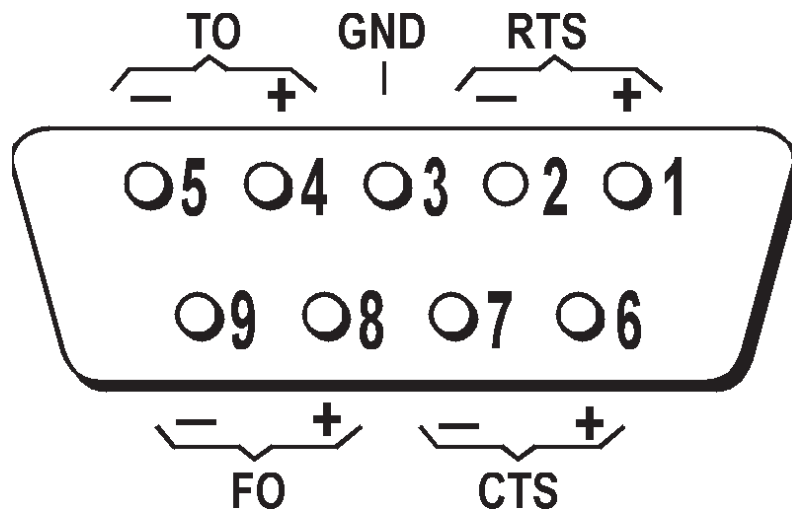
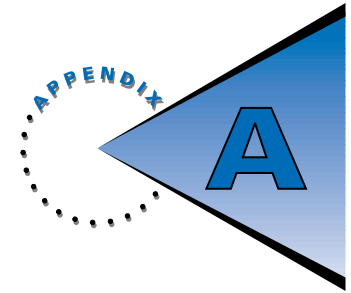
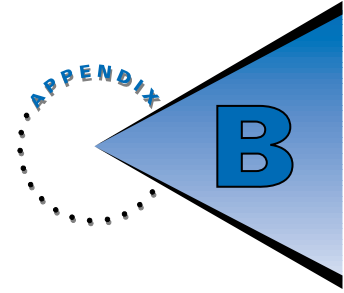


Figure A-1: AC7A/B DB9 (J2) Connection Pinout

# PRODUCT SUPPORT



If you have any questions about this product, contact Opto 22 Product Support Monday through Friday, 8 a.m. to 5 p.m. Pacific Time.

<b>Phone:</b>	800/TEK-OPTO (835-6786) 909/695-3080
<b>Fax:</b>	909/695-3017
<b>E-mail:</b>	support@opto22.com
<b>Bulletin Board System (BBS):</b>	909/695-1367 <a href="http://bbs.opto22.com">http://bbs.opto22.com</a> (24 hours a day, 7 days a week)
<b>OptoWorld Wide Web site:</b>	<a href="http://www.opto22.com">http://www.opto22.com</a>
<b>OptoExpress:</b>	<a href="http://www.optoexpress.com">http://www.optoexpress.com</a>

When accessing the BBS, use the following modem settings:

- No parity, 8 data bits, 1 stop bit
- Baud rates up to 28,800
- Z-modem protocol for uploads and downloads (optional but recommended)

When calling for technical support, be prepared to provide the following information about your system to the Product Support engineer:

- Software and version being used
- Controller firmware version
- PC configuration
- A complete description of your hardware and operating systems, including:
  - jumper configuration
  - accessories installed (such as expansion daughter cards)
  - type of power supply
  - types of I/O units installed
  - third-party devices installed (e.g., barcode readers)
- Specific error messages seen